

Easy Gripper 2160

Tyre diameter
 700 - 2.160 mm
 28 - 85"

Lift capacity
 1.000 kg
 2.200 lbs

Easy Gripper 2400-2T

Tyre diameter
 850 - 2.400 mm
 34 - 94"

Lift capacity
 2.000 kg
 4.400 lbs

Basic feature:

Short
Solid
Extra tilt

Easy Gripper Crane Module B

**Save time
Improve safety**



Professional tools for mobile tyre service with truck cranes

- Unique 3-point grip
- Horizontal/vertical tilt
- Precise rotation +/-25°
- Tools for safe handling of tyre rings
- Prevent damage to tyres, rims & equipment
- Easy hook on/off attachment
- Customization available



Experts in Tyre Handling Equipment



Mobile service of OTR/EM and AGRO tyres

The Easy Gripper product range is designed to help tyre professionals in a multitude of conditions and situations. Implementing the Easy Gripper makes tyre handling faster and safer, while preventing damage to tyres, rims and equipment.

Installed on a truck crane, the Easy Gripper offers the optimal flexibility allowing the driver to be able to both transport and mount the big OTR or AGRO tyres and wheels – and even single-handedly.

With the Gripper very risky and time-consuming handling situations become safe and easy.



Safe 3-point grip

The unique 3-point grip offers optimal grip and control, when handling tyres and wheels. Together with the precise rotation and tilt functions hard and dangerous work can be avoided as well as damages on tyres, rims and equipment.

Quick shift & remote control

The Easy Gripper Crane Module can easily and quickly be mounted on the truck crane with a quick shift system. Further, the remote control system can easily be incorporated in the control system of the crane.



Solution for narrow space

Limited clearance around tyres and fenders can quickly be solved. By loosening just one bolt, the top pipe can be exchanged with a flat top arm, and the two bottom pipes carry the tyre below the fender.

Light and compact

The Gripper has a light and compact design to optimize the center of gravity and the load capacity of the crane and of the total solution. The Crane Module gives the configuration a tilt function up to 180°.



Capability

With a gripping range of Ø850 - 2.400 mm (34 - 94") and a lifting capacity of 2 ton (4.400 lbs) at a CoG of 550 mm (22"), the Gripper can handle tyres up to 37.25R35. When handling full wheel assemblies as inside duals, the Gripper handles up to 24.00R35 tyres.

If you don't handle wheel assemblies bigger than 1 ton (2.200 lbs) and a gripping range of Ø700 - 2.160 mm (28 - 85") , you can choose a configuration with our Easy Gripper 2160, where we on request also can extend the gripping diameter to Ø2.400 mm (94") to handle even the biggest AGRO tyres.

Standard features

Handles both the Easy Gripper 2160 and 2400-2T

Unique and safe 3-point grip

Avoid accidents.

Avoid deformation and damages of tyres.
Avoid damages to tyres, rims and equipment.

Precise rotation +/-25°

Tilt function up to 180°

Control system designed to be integrated with existing crane control system

Required accessory

Compact Mounting Plate with Quick Shift System

For easy hook on and off attachment.

Can be customized pre-angled depending on carrier.



Telescopic pipes for long reach



Flat top arm for limited tyre clearance



Tools for safe handling of tyre rings



LED working light

Optional accessories

LED working light (2400-2T only)

Camera system for optimal view

With automatic IR function in insufficient light conditions

Easy shift of gripping pipes for various purposes

Flat top arm for limited tyre clearance.

Telescopic pipes for long reach, to provide room for the tyre fitters and for dual tyre handling.

Tools for safe handling of tyre rings

To help tyre fitters with the hard and dangerous work.
Can easily be attached at the end of the gripping pipes.
Can push the tyre and can hold and place the rings.

Customization on request

Technical Data	Easy Gripper 2160	Easy Gripper 2400-2T
Gripping diameter:	700 - 2.160 mm (28 - 85")	850 - 2.400 mm (34 - 94")
Standard pipes:	Ø89 x 600 mm (3.5 x 24")	Ø115 x 650 mm (4.5 x 26")
Lifting capacity:	1.000 kg (2.200 lbs)	2.000 kg (4.400 lbs)
Weight:	905 kg (1.995 lbs)	1.110 kg (2.447 lbs)
CoG Gripper: A	785 mm (31")	900 mm (35")
Rear of Load: B	1.280 mm (50")	1.330 mm (52")
CoG Load: C	1.780 mm (70")	1.880 mm (74")

Technical Requirements

Insert for mounting:	Crane specific	Crane specific
Lifting capacity:	Individual calculation	Individual calculation
Electrical supply:	12/24 V	12/24 V
Hydraulic flow max:	50 L/min (13.2 gal)	50 L/min (13.2 gal)

One, or preferable two, hydraulic proportional valves to control the Crane Module and the Gripper.

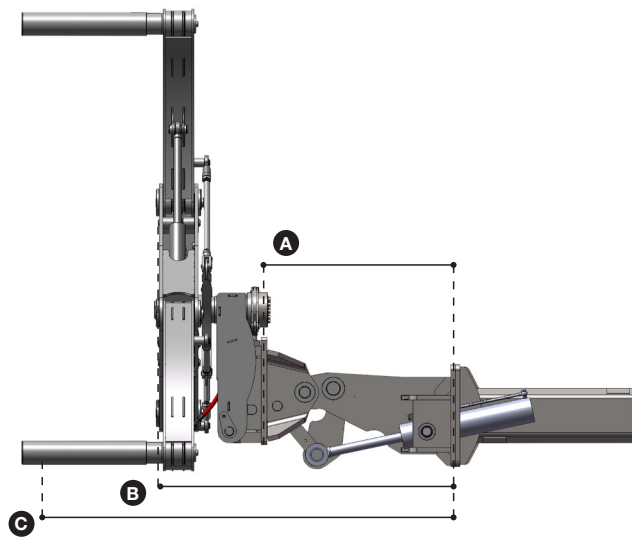

Authorized Dealer

JET150VPERFORME-MODULE-REV.03.11.2020



+45 72 344 344
 info@justeasytools.dk
 www.justeasytools.com
 VAT no.: DK33644809

Just Easy Tools ApS
 Nupark 51
 DK-7500 Holstebro
 Denmark